

HUIYA BARE SC2000

BRONZE-2000LBS (SC2000) TECHNICAL DATA SHEET

HUIYA Bare SC2000 steel cementitious raised access floor offers exceptional fire and load resistance, excellent sound absorption, and stability in humid environments. It is suitable for a variety of interior applications requiring an elevated system. It also offers high technical and aesthetic adaptability. HUIYA Bare SC2000 raised access floor system consists of two steel plates welded together by electric current, injected with lightweight foamed cement, and coated with a smooth epoxy anti-corrosion coating.



Outstanding static and live load performance



Panel design allows for fast and precise installation



Non-Combustible



Moisture Resistant



Patented design features create a quiet and comfortable underfoot solution



Excellent Earthing Continuity

BARE SC2000 SYSTEMS

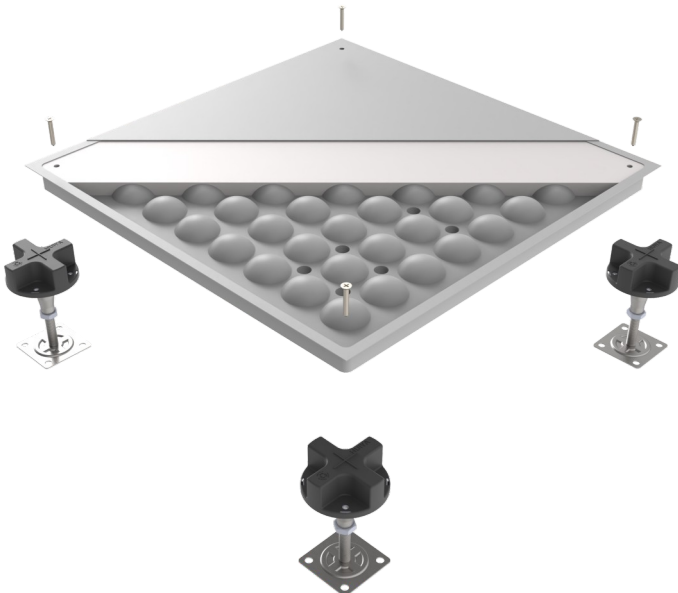

PANEL DIMENSIONS:

Size: 600x600mm

PANEL THICKNESS:

DEPTH 35mm

PANEL CORE:

Steel encapsulated and cement injection compound.

CORROSION RESISTANT PROTECTION:

Standard epoxy resin powder coated finish.

BARE FOR FINISHING:

The raised floor is fixed with screws and various types of floor coverings can be laid after installation.

TOLERANCE:

±0.25mm and a flatness tolerance of ±0.5mm measured diagonally across the panel surface.

PEDESTAL:

Solid and stable raised access floor structure consisting of steel pedestals, stringers (optional) and screws with height ranging from 60mm-2000mm.

SOUND INSULATION GASKET:

Each pedestal contains flame-retardant sound insulation gasket to reduce friction between the metal pedestal and the metal raised access floor, thereby reducing noise generation.

SUITABLE FINISHES

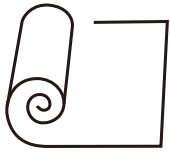

Carpet

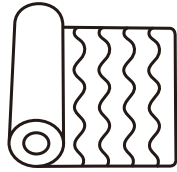

Vinyl

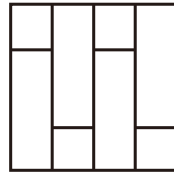

Plank Wood



Rubber

SYSTEM ASSEMBLY

HUIYA RAISED ACCESS FLOOR is extremely easy to install on indoor construction sites. Each **RAISED ACCESS FLOOR** is fastened with screws, and the pedestal at the bottom of the floor is height-adjustable. This system ensures fast and efficient installation. The pedestal head features a black positioning gasket, providing unique sound insulation and vibration damping properties. The pedestal base is bonded with Japan's **KONISHI KU928** pedestal adhesive, which is environmentally friendly and formaldehyde-free.

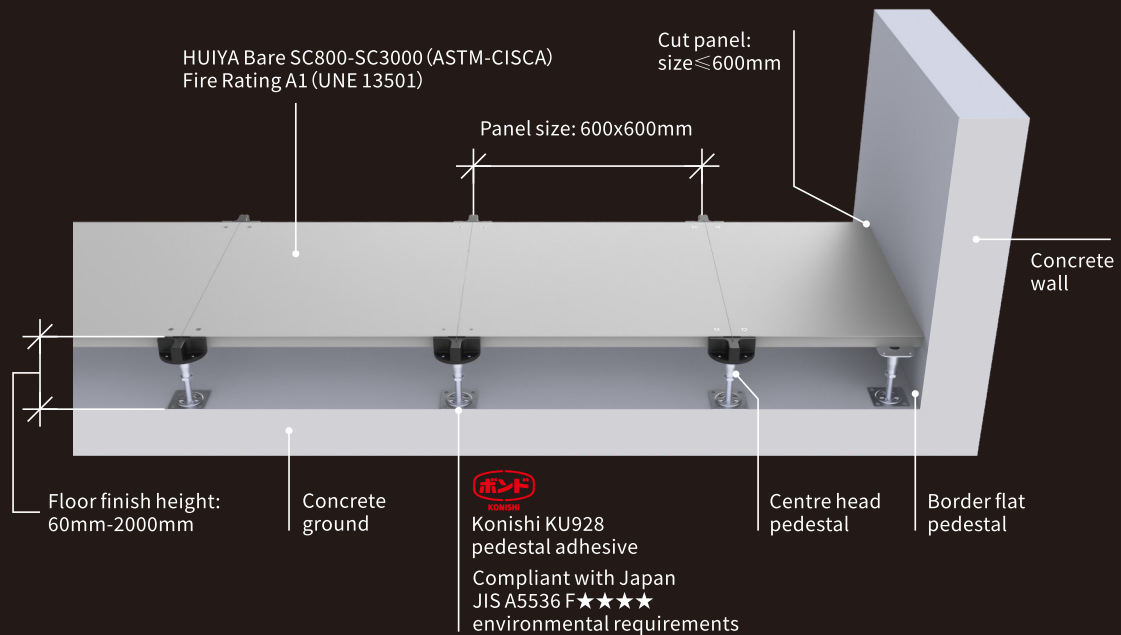

INSTALLATION METHODS

1. Measure the length and width of the room. For example: the room length is 6500mm and the floor size is 600mm. By calculation, 10 pieces of 600mm full-size panels+one 500mm cut panel are needed (500mm is split into 300mm and 200mm for wall edge installation). The same principle applies to room width direction measurement.

2. Start installation the full size raised access floors panel 300mm away from the wall in the length direction. After installation 10 pieces, measure the remaining two perimeter areas and cut the panels to fit the wall line, and finally installation of the edge panels is completed. The same principle applies to width direction.

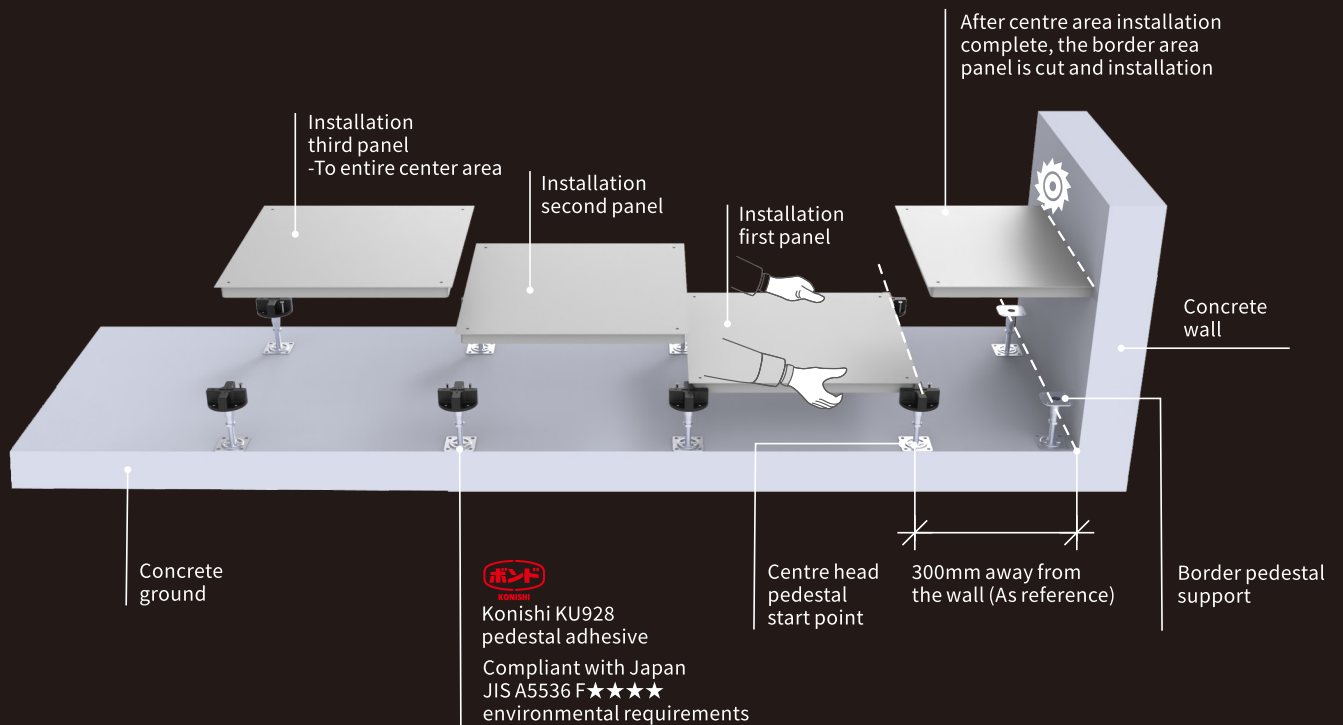

AREAS OF APPLICATION



Commercial Office Buildings



Banks



Learning Institutions



Libraries



Casinos

BARE SC2000 PANEL INTRODUCTION

★ Panel Size	mm	600mm (length) × 600mm (Width) × 35mm (Thickness)	
★ Steel top plate thickness	mm	1.2	
★ Steel pan bottom thickness	mm	1.8	
★ Epoxy resin powder coating	μm	80	
★ Weight per panel	kg	19.1	
★ Weight per sqm (Structure finish height included 300mm)	kg	54.7 Without stringer	56.0 With stringer

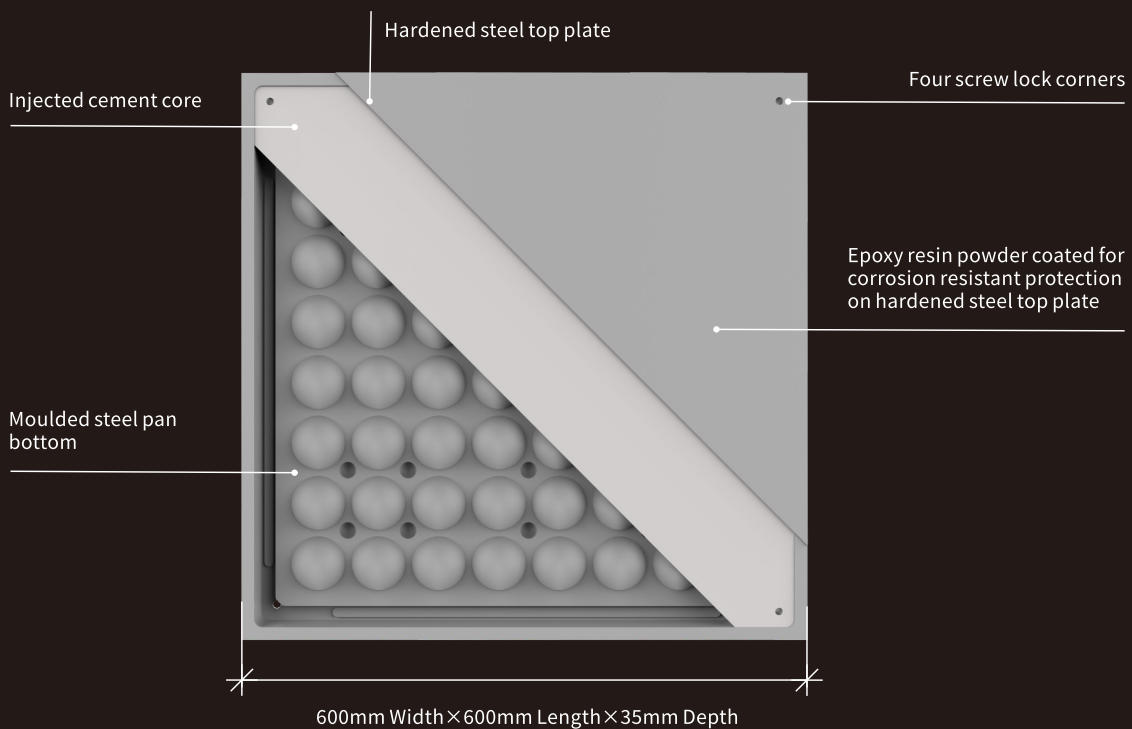
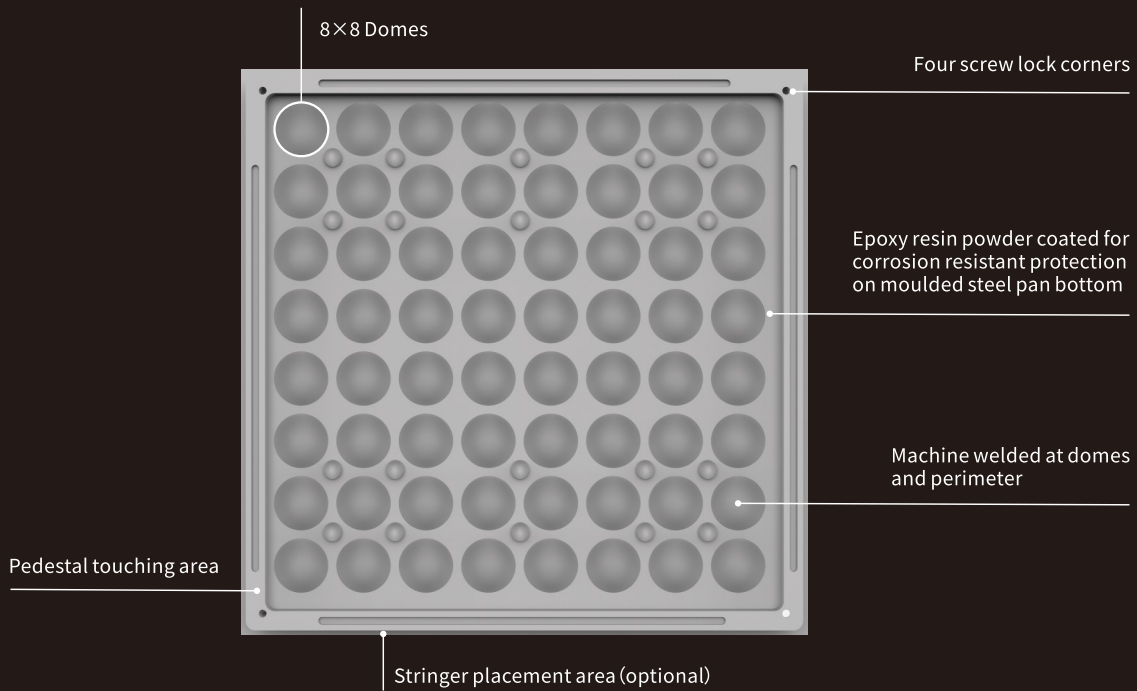

GENERAL CHARACTERISTICS

Bare SC2000 Characteristics

Ultimate load	KN	> 18.1
Concentrate load (Design load) Deflection at design load (Max. 2.5mm)	KN	9.0
Safety factor		3.0
Uniform load (Distributed load)	KN/m ²	45.3
Impact load (Sand bags impact and panel without broken)	KG	91

Fire resistance	ASTM E136-11	No combustion or ignition
	ASTEM E84-14	Class A
	EN13501-1:2002	A1
Acoustic performance	ASTM E492-09	Calculated impact insulation class: IIC 58

Concentrate load (Design load)

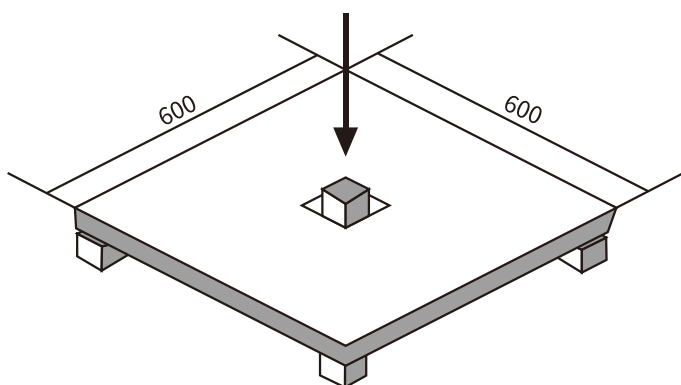

Impact load

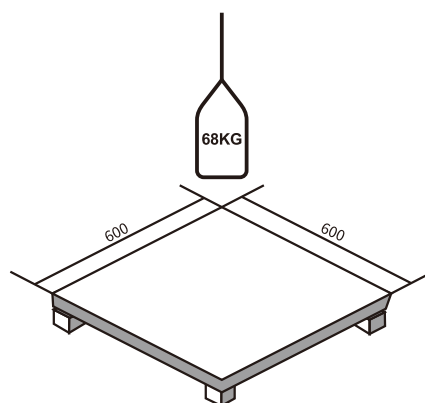

Uniform load (Distributed load)

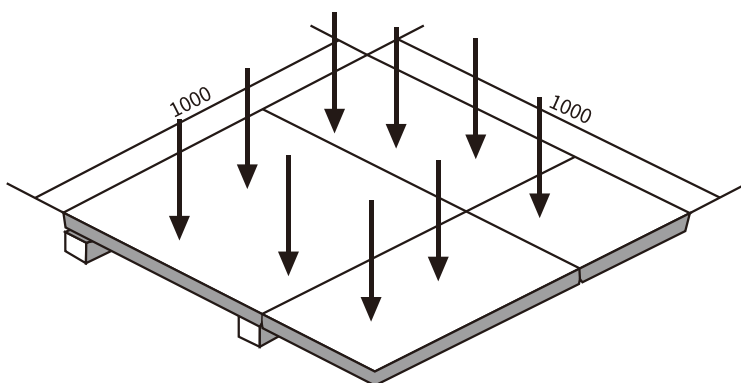

Fire resistance

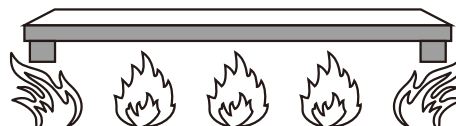

Acoustic performance

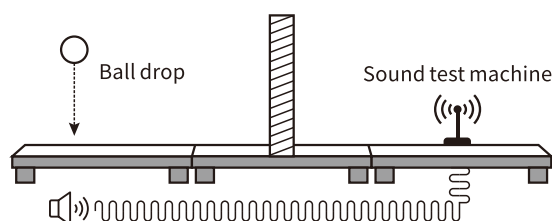

UNDER-STRUCTURE CLASSIFICATIONS

H60-150mm HUIYA **New Design**[★] Pedestal Type

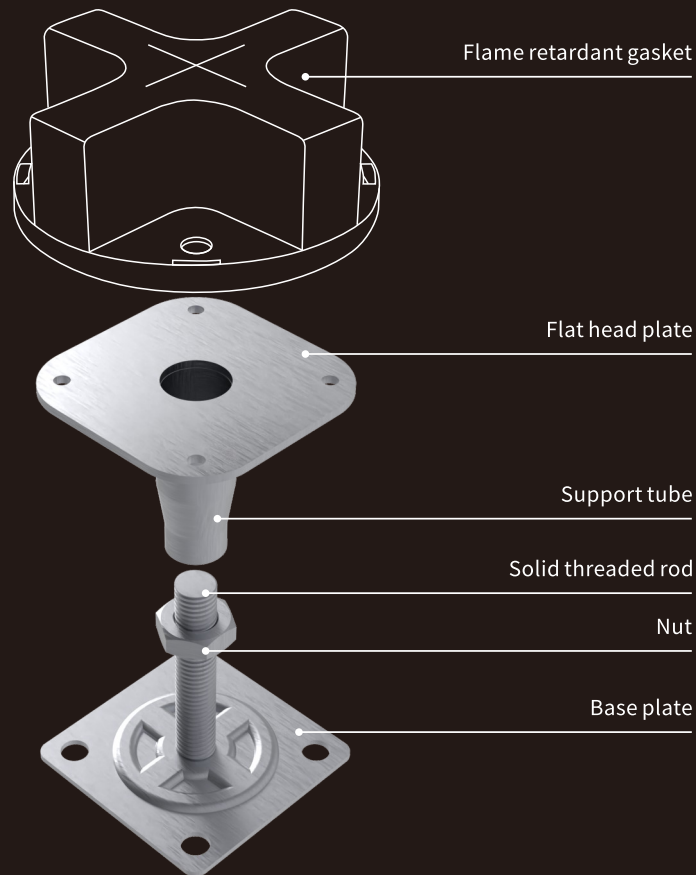

H60-150mm Pedestal Type Description			
No.	Elements	Dimensions (mm)	Heights
1	Flat head plate	80mm×80mm×3mm Thickness	Nominal heights from 60mm-150mm Adjustments: +/-25mm
2	Threaded rod	M18	
3	Nut	1	
4	Support tube	Φ25×1.5mm Thickness	
5	Base plate	90×90×2mm Thickness	
6	Flame retardant gasket	Φ100×1.5mm	

UNDER-STRUCTURE CLASSIFICATIONS

H150-250mm HUIYA **New Design**^{*} Pedestal Type

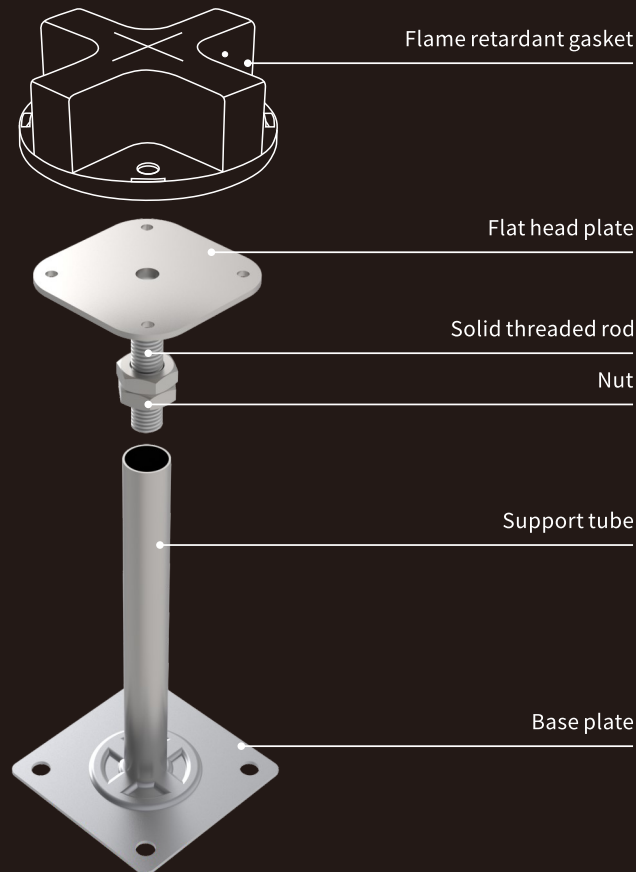

H150-250mm Pedestal Type Description			
No.	Elements	Dimensions (mm)	Heights
1	Flat head plate	80mm×80mm×3mm Thickness	Heights from 150mm-250mm Adjustments: +/-25mm
2	Support tube	Φ22mm, thickness:1.5mm/or Φ25mm, thickness:1.2mm with a extra black plastic plug	
3	Threaded rod	M18	
4	Nut	2	
5	Base plate	100mm×100mm×2mm Thickness	
6	Flame retardant gasket	Φ100×1.5mm	

UNDER-STRUCTURE CLASSIFICATIONS

H60-150mm Traditional Aluminum Pedestal Type(Centre Pedestal)

H60-150mm Traditional Flat Head Border Pedestal Type

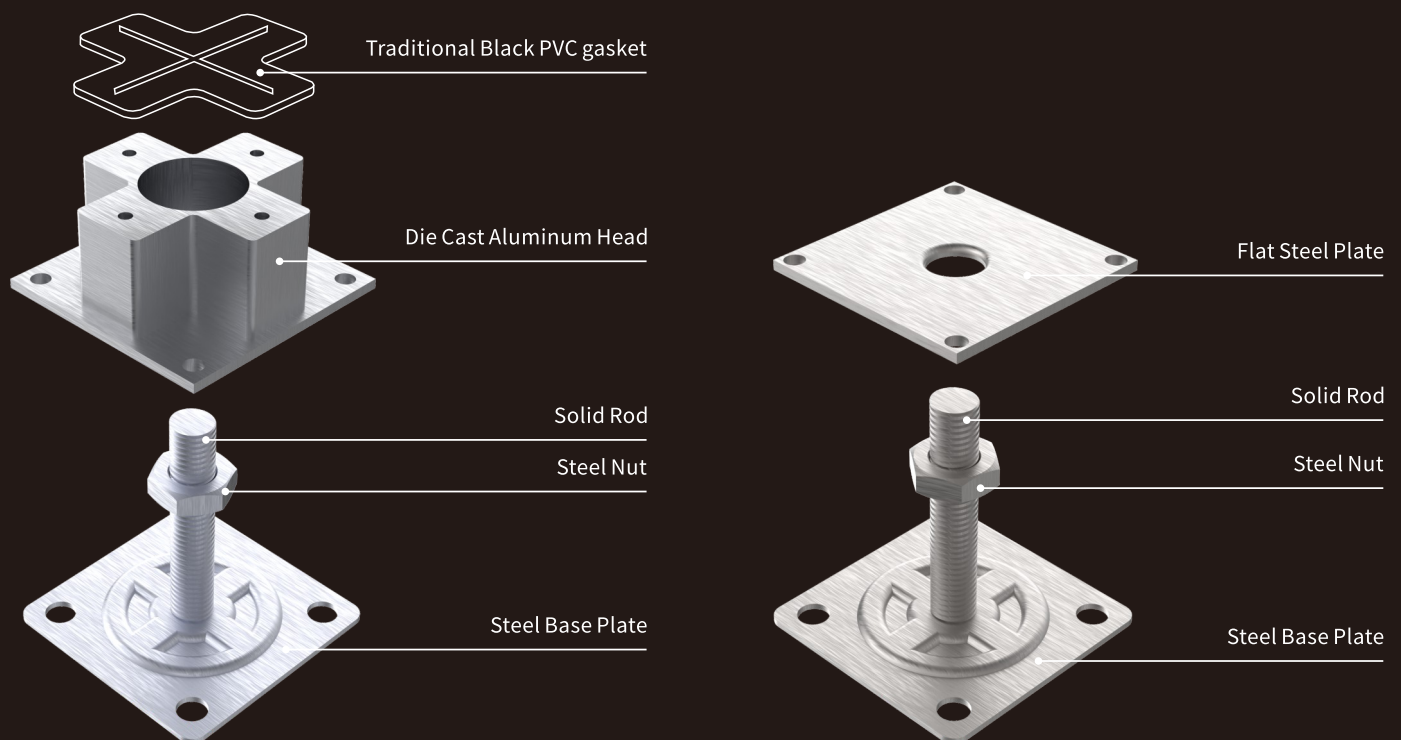

H60-150mm Traditional Pedestal Type (Centre Pedestal/Border Pedestal) description

No.	Elements	Dimensions (mm)	Heights
1	Head	Centre Pedestal: 70mmx70mm Dia-cast Aluminum Head, 3.0mm Thickness (Aluminum Head Weight: 83-85g/piece) Border Pedestal: 75mm×75mm Steel Flat Head,3.0mm Thickness	Nominal Heights from 60mm-150mm Adjustments: +/-25mm
2	Threaded rod	M18	
3	Nut	1	
4	Base plate	95mm×2mm	
5	Gasket	Traditional Black PVC gasket	

UNDER-STRUCTURE CLASSIFICATIONS

H150-250mm Traditional Aluminum Pedestal Type (Centre Pedestal)

H150-250mm Traditional Flat Head Border Pedestal Type

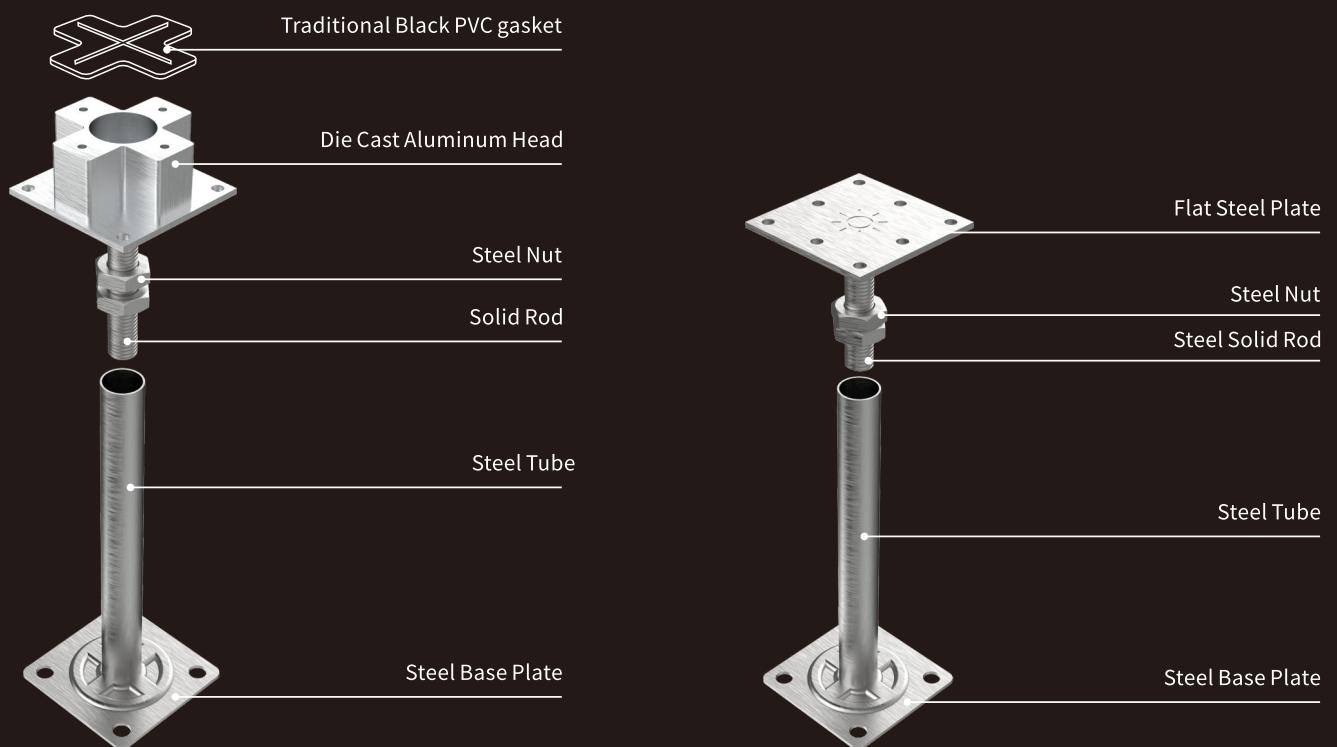

H150-250mm Traditional Pedestal Type (Centre Pedestal/Border Pedestal) description

No.	Elements	Dimensions (mm)	Heights
1	Head	Centre Pedestal: 70mmx70mm Dia-cast Aluminum Head, 3.0mm Thickness (Aluminum Head Weight: 83-85g/piece) Border Pedestal: 75mm×75mm Steel Flat Head,3.0mm Thickness	Nominal Heights from 150mm-250mm Adjustments: +/-25mm
2	Threaded rod	M18	
3	Nut	2	
4	Steel Tube	Φ22mm, thickness:1.5mm/or Φ25mm, thickness:1.2mm with a black plastic plug	
5	Base plate	95mm×95mm×2mm	
6	Gasket	Traditional Black PVC gasket	

UNDER-STRUCTURE CLASSIFICATIONS

H250-2000mm Pedestal Type

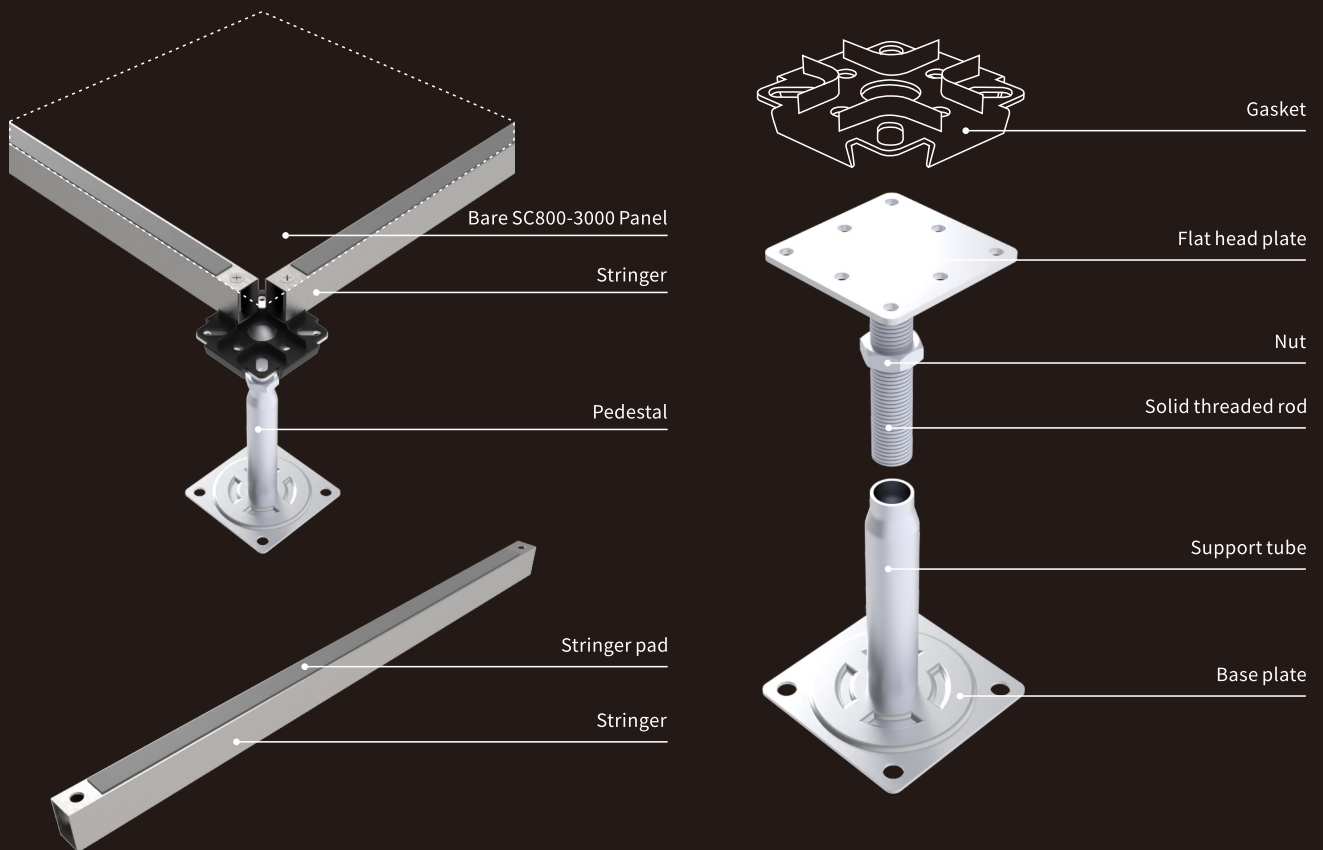

H250-2000mm Pedestal Type			
No.	Elements	Dimensions (mm)	Heights
1	Flat head plate	75mm×75mm×3mm thickness, 75mm×75mm×4mm thickness	Heights from 250mm-2000mm Adjustments: +/-25mm
2	Threaded rod	M18/M20	
3	Nut	1 or 2	
4	Support tube	Φ22×1.5mm Thickness, Φ25×1.2mm Thickness, Φ32×1.5mm Thickness, Φ48×1.5mm Thickness	
5	Base plate	95×95×2mm Thickness, 100×100×2mm Thickness, 125×125×3mm Thickness, 125×125×4mm Thickness	
6	Gasket	76×76×1.5mm thickness	
7	Galvanized stringer	570mm Length×32mm Width×21mm Height, Thickness:1.0mm	
8	Stringer pad	1	
9	Screws	M6×40mm	

BOND KU928C-X RAISED ACCESS FLOOR ADHESIVE

BOND KU928C-X is a high-performance, one-component, moisture-curing polyurethane resin adhesive suitable for bonding various raised floor steel and plastic pedestal. This product is VOC-resistant, free of 13 indoor substances harmful to human health, and contains no added VOCs (volatile organic compounds). Furthermore, the cured coating of BOND KU928C-X exhibits moderate elasticity, effectively preventing floor and pedestal noise issues associated with raised floor construction.

Conforms to Japanese JIS A 5536 F☆☆☆☆ standards

- Excellent adhesion to various metal pedestal and wood flooring materials.
- Effectively prevents friction noise from raised floor pedestal.
- Contains no harmful solvents and is virtually odorless.
- Non-hazardous and highly fire-resistant.
- Excellent water, fire, and oil resistance, making it suitable for wet area applications.
- Compatible with disposable glue containers.

Main Ingredients: Solvent-free polyurethane resin
Appearance: Pale yellowish-white paste



Patented design: The glue container has a built-in scraper design function, which can be used with KONISHI Ku928 adhesive to be squeezed into the container. The glue container can just hold one Ku928 adhesive. The glue box is a disposable product and is used for large-area paving of raised floor construction sites.



BOND STRENGTH

Bonding test between pedestal and concrete slab (KONISHI KU928 pedestal adhesive)	
24-hour adhesive strength (N)	7-day adhesive strength (N)
2750	3483



